



International Journal of **Design Sciences & Technology**

Volume 17 Number 2

ISSN 1630 - 7267

Editor-in-Chief:

Reza Beheshti
Khaldoun Zreik

Phan, V.T. and Choo, S.Y. (2010). Developing outdoor augmented reality for architecture representation in educational activities, International Journal of Design Sciences and Technology, 17:1, 121-135



ISSN 1630 - 7267

© **Europa**, 2010

15, avenue de Ségur,
75007 Paris, France.

Tel (Fr) 01 45 51 26 07 - (Int.) +33 1 45 51 26 07

Fax (Fr) 01 45 51 26 32- (Int.) +33 1 45 51 26 32

E-mail: ijdst@europa.org

<http://www.europa.org/ijdst>

Developing outdoor augmented reality for architecture representation in educational activities

Viet Toan Phan* and Seung Yeon Choo**

* Kyungpook National University, Korea. Email: toanpv_xdcn@yahoo.com

** HaNoi University of Science & Technology, Viet Nam. Email: choo@kni.ac.kr

This work examines an application of Augmented Reality (AR) for architectural education and fire prevention training for Korean Traditional Buildings. In February 2008, the Namdaemun Gate (Korean National Treasure N° 1) burned down, despite efforts of many firemen, as the main difficulty was getting fire under control without any structural knowledge of wooden buildings. Hence, in state of the art of digital technology, an application of virtual information to traditional buildings is needed, and AR is already being considered as new design approach for architecture. In this example, outdoor AR is another practical application that takes advantages of Wearable Computer devices to superimpose virtual graphics of traditional buildings in real outdoor scenes. Plus, outdoor AR also allows user to move freely around and through inside virtual building, thereby offering intuitive training opportunities for architects, archaeologist, firemen, etc. For study case, the prototype AR system demonstrates its ability to assist firemen in their mission.

Keywords: augmented reality, Asian wooden building, GPS, wearable PC, markerless AR

1 Introduction

The Namdaemun Gate is one of the most famous wooden structures in the Republic of Korea. Its construction began in 1395 during the fourth year of the reign of King Taejo from the Joseon Dynasty, and was completed in 1398. Over the next six centuries, the Gate underwent several renovations with the last major repairs conducted in 1962, when the Korean government designated it as “National Treasure N° 1”.

Unfortunately, on February 10, 2008, the Gate was completely destroyed by fire, despite the efforts of over 360 fire-fighters. Due to the complex hermetic structure of the Gate, the jets of water were unable to reach the centre of the fire, making the rescue attempts useless. However, if the fire-fighters had been able to see a virtual model of the traditional building, it could have provided valuable information for more effective rescue strategies. In fact, various graphic technologies already exist that could provide such support.

Extensive research has already been conducted on the application of CAD to Historical and Cultural buildings, for example, 3D Laser Scans, GIS, and VR. Plus, 3D graphic applications have played an important role in the design and restoration of several heritage projects. Among such applications, Augmented Reality is a new technology that enables the interaction of 3D computer graphics in a real world context real-time. As such, the user is not limited to viewing the real world augmented with virtual objects generated by computer graphic software, but can also interact with those virtual objects in real-time. One example of the application of AR to Cultural Heritage projects is the Archeoguide¹ that allows the user to see the completely re-generated virtual temple of Hera in Greece superimposed over the surviving ruins and the ARQuake game^{2,3} is another ex-

1 Cultivate Interactive (2003). Augmented Reality Touring of Archaeological Sites with the ARCHEOGUIDE System, Cultivate Interactive Organization [www.cultivatint.org/issue9/archoeguide/index.html]

2 Pierkarski, W. et al (1999). Integrating Virtual and Augmented Realities in an Outdoor Application. In: Proceedings of the 2nd IWAR, IEEE, Washington DC, pp. 45-54

3 Thomas, B. et al (2000). ARQuake: An Outdoor/Indoor Augmented Reality first person application. In: Proceedings of the 4th International Symposium on Wearable Computer, IEEE, Atlanta, GA, pp. 139-146

4 Zalatanova, S. (2002). Augmented Reality Technology, GIS St N°17, GIS Technology, TU Delft, The Netherlands

ample of using outdoor AR paradigms to provide a re-generated game scenario based on a real environment. Yet, these projects focus on the viewing process through only Head Mounted Display (HMD) and are just intended for tourism or entertainment purposes. Accordingly, this study examines the use of AR technology as a new tool for protecting and maintaining traditional buildings, including emergency situations. Thus, the Namdaemun Gate was selected as a case study and “built up” using an outdoor AR technique with a mobile AR system. The prototype AR system also performs another implementation manner beside current outdoor AR systems, gathers flexible functions and technical information supporting capabilities. A wearable PC device set is also proposed for use in emergency situations.

2 Overview of Augmented Reality technology

Augmented Reality (AR) is a new technology that involves the overlay of computer graphics on the real world. As a result, the user can see the real world augmented with virtual objects, and can also interact with these virtual objects. AR is also grouped under the umbrella term Mixed Reality (MR), which refers to a multi-axis spectrum of areas that cover Virtual Reality (VR), Augmented Reality (AR), telepresence, and other related technology (Figure 1).

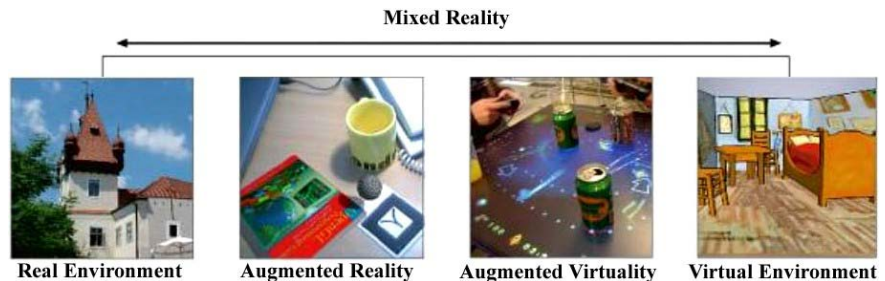

Figure 1 Paul Milgram's Reality Virtual Continuum

Augmented Reality systems combine digital information and the real world in a way that the user experiences them as one. A particular important property of AR is locating virtual objects in the right place and position, which makes the Tracking System one of the most important components of an AR system. Essentially, an AR system must be able to follow the user's point of view dynamically and keep virtual objects aligned with real world objects. The basic components of an AR system are a display, camera, and computer with application software, plus various different kinds of hardware can be used, for example, camera phones, PDAs, lap-tops, HMDs, and wearable computer systems (Figures 2 and 3).

Although Augmented Reality has only been studied for one decade, the growth and progress in the past few years have been remarkable. As such, AR technology has many possible applications across a wide range of fields, including entertainment, education, medicine, military training, engineering, and manufacturing.⁴

It is also expected that other potential areas for application are still to appear with the dissemination of this technology. During the early stages, the main focus of AR development was related to hardware technology rather than usability. How-

ever, the rapid development of mobile devices (handheld) with better processing capacities and long-lasting batteries has increased the potential of lightweight mobile AR systems. Thus, mobile AR devices are now one of the most promising emerging technologies for developing AR in an outdoor environment. Therefore, this study presents an outdoor AR system housed in a backpack for use by fire-fighters. It utilizes a wireless network environment and GPS localization.



Figure 2 AR applications in entertainment medical fields



Figure 3 AR applications in military and civil engineering fields

2.1 Outdoor Augmented Reality and technical challenges

Although many AR systems have been developed in recent years, the majority of systems are intended for small indoor environments, where the conditions are easier to control (e.g. brightness variation, occlusion, 3D registration). However, outdoor AR is also an important application area for AR technology, where virtual graphics are superimposed on an outdoor scene. In particular, outdoor AR requires the virtual graphics process that generates the overlay to withstand many unstable effects from environmental elements in real-time, while also allowing the user to move freely around the real site for observation.

Despite this, recent advances in computer vision and mobile computing can now facilitate the development of more complex AR applications for outdoor environments, where working conditions are hard to control (sunlight, unrestricted mobility, etc.) and where different types of tracking sensors (GPS sensor, compass sensor) can be used. Notwithstanding these developments, outdoor AR still presents several problems that are the subject of intense research, including 3D localization, visualization, interaction on mobile devices, and the use of geo-

5 Azuma, R. (2000). The challenge of Marking Augmented Reality Work Outdoors. In: Ohta Y. & Tamura H. eds, *Mixed Reality: Merging Real and Virtual World*, Springer-Verlag, Japan, pp. 363-384

6 Cultivate Interactive (2003). *ibid*

referenced data. Thus, the development of an outdoor AR system presents real challenges in terms of technology, methodology, and industry.⁵

The technological issues related to outdoor AR mainly involve the development of new techniques in the fields of localization, 3D visualization, and interaction on handheld devices. The mobility of the user in an unrestricted and unprepared environment makes the localization process difficult. Usually, outdoor AR techniques combine an absolute location and relative location to provide continuous user localization. Absolute location involves estimating the user's position using for example GPS, whereas relative location uses the motion of a sensor, like an accelerometer or gyroscope, to estimate a relative displacement of the user with regard to a reference position. 3D models of the environment are typically used to initialize the localization procedure. However, the problem of accurate localization in a natural environment and 3D registration (unknown surrounding, multiple sources of information, risk of occultation) is still an active field of research.

In addition, outdoor AR applications need a realistic 3D virtual representation of the real environment. While 3D models are very useful for pose estimation from 2D/3D matching, the construction of simple and rich 3D models remains a major challenge for AR.

The information available to user on site is normally huge. However, to display such data in real-time on a display device with limited processing power and low storage space is another problem that arises in the case of mobile AR. Thus, the recent development of a wearable PC is of particular value to the development of outdoor AR and will be examined in this study.



Figure 4 Outdoor AR view of Hera temple in ancient Olympia, Greece

2.2 Application of outdoor Augmented Reality

The field of cultural heritage involves the restoration or re-generation of many traditional buildings at the original sites based on surviving ruins. Restoring a virtual model of traditional building in an outdoor environment provides 3D graphics to architects or archaeologists, so that they can see beforehand what problems of building (or restoring) work in near future are required. One good example of the application of outdoor AR for Cultural Heritage is the Archeoguide⁶ project that provides visitors with a simulated view of ancient Greece when they are at the actual historical site (Figure 4).

7 Stricker, D. & Kettenbach, T. (2000). Real-time and Markerless Vision-based Tracking for Outdoor Augmented Reality Applications. In: Proceedings of ISAR'01, IEEE, Washington, pp. 189

However, the present study examines the use of outdoor AR to create a 3D model for the purpose of re-simulating a 3D model of Korean traditional building at a real historical site in outdoor environment. In addition, it is also intended that this application of outdoor AR can be used to provide practical training information for firemen, for example, on the structure of traditional wooden buildings, and since AR technology can provide user interaction in real-time, it is also hoped that the proposed AR system will be able to help guide firemen in the case of real emergencies.

However, the real valuable advance of this study is the prototype AR system that allows the user to interact with a virtual building with more flexibility and with capacity to view the full supporting technical information of the building. Especially important, the user can move freely around while observing the building from many directions. Further, the AR system can support an AR aviation view. The study produced several results, which will be presented in the following sections of this paper.

3 AR use for education and fire protection

3.1 GPS and compass- based position & orientation tracking

To integrate virtual objects into a real environment, a tracking system is needed to determine the user's exact position and direction of view. However, despite the availability of many tracking technologies that offer position and orientation tracking with high precision and low latency, none of these systems are suitable for outdoor usage with the precision required by the present application. Thus, integrating different tracking technologies into one hybrid system would seem to be the most promising method.

First, a rough positioning of the user is achieved by using GPS and a compass system,⁷ while the exact tracking system is based on vision-based tracking (reference images based tracking).

The only additional hardware needed to perform the vision-based tracking is a small off-the-shelf camera attached to the user's Head-Mounted Display (HMD) and a frame grabber integrated in the Mobile Unit. As such, the tracking system determines the user's viewpoint based solely on video images. The system is developed based on the idea of image registration, which is a global method that takes into account the whole image of the user's field of view.

The method assumes that a large number of calibrated images are stored in a database, indexed according to the spatial coordinates from which they were taken. The method then computes a comparison between the current user image (taken from the camera) and a number of site images in the database whose indexes are close to the coordinates provided by the GPS and compass devices. The matching is done by considering the image as a whole (global method), instead of identifying landmarks in each image (local method). When the area of the two images being compared overlap by approximately 40% or more, the method can correctly compute the warping transformation of one image to the other. This transformation is then used to provide accurate head-pose estimation, as the coordinates of the database image are already known. In fact, in the case when there are pre-rendered images of 3D reconstructions of traditional buildings rendered from the same point of view as the stored site images, the same warping transformation can be used to transform (fast and accurately) the pre-rendered

image and then display it on the user's HMD, thus achieving 3D visualization as well.

Results for this approach have already been measured when tracking at a speed of 10 frames per second on a low-end desktop PC, and several optimizations are being developed to increase this speed to 20-30 frames per second. Therefore, this approach would seem to hold the best promise for accurate head-pose estimation in wide outdoors areas. In contrast to landmark recognition-based methods, which can fail to track due to occlusions of the landmarks from the user's point of view (due to other objects, such as humans and animals, obstructing the user's field of view), this image registration-based tracking method is far more robust, as it is a global method requiring any overlap in the image of only 30-40%.

The GPS information helps in the case of calibration and recalibration. Plus, the GPS and compass information aid in predicting the user's path and which direction they will approach in order to prepare which data to use next.

Therefore, the proposed method avoids the necessity of an accurate 3D model database and makes use of an image-based rendering technique.

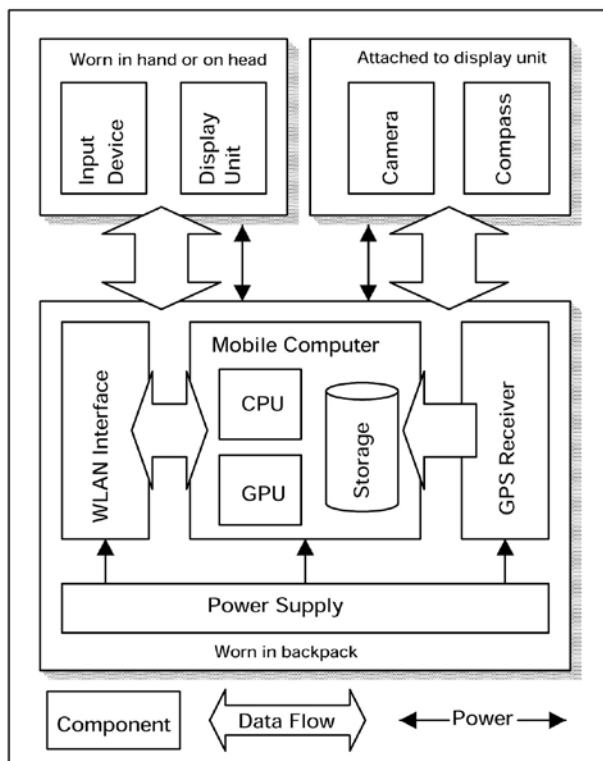

Figure 5 Mobile Unit system architecture

3.2 System structure

As the Mobile Unit (MU) needs to be easily carried by the user on site, it must be small, lightweight, and easy to handle, even for unskilled users (Figure 5). Thus, it has to be an intuitive wearable or portable device. Furthermore, since the

current case study is for use by firemen, the system must also be robust enough to withstand severe outdoor conditions and be cost effective.

The connection is also another important issue, as many peripheral devices need to be attached to the main module. First of all, a display unit, such as a Head-Mounted Display (HMD) or portable liquid-crystal display (LCD), with a reasonable resolution is required. These devices are used to present the augmented images of the reconstructions as well as the system's user-interface. In order to interact with this system, a mobile input-device has to be provided. A touch-screen integrates best with a portable LCD solution, yet the use of an HMD glass requires an extra device to make it easy to use in an outdoor environment.

In outdoor AR, the user position is determined using a Global Positioning System (GPS) and the user orientation primarily based on information from an electronic compass. The position and orientation tracking is facilitated by a web camera and an electronic compass both mounted on the HMD, capturing and measuring the user's current field of view. Furthermore, a GPS receiver determines the mobile user's position on-site delivering rough initial estimates to the tracking software.

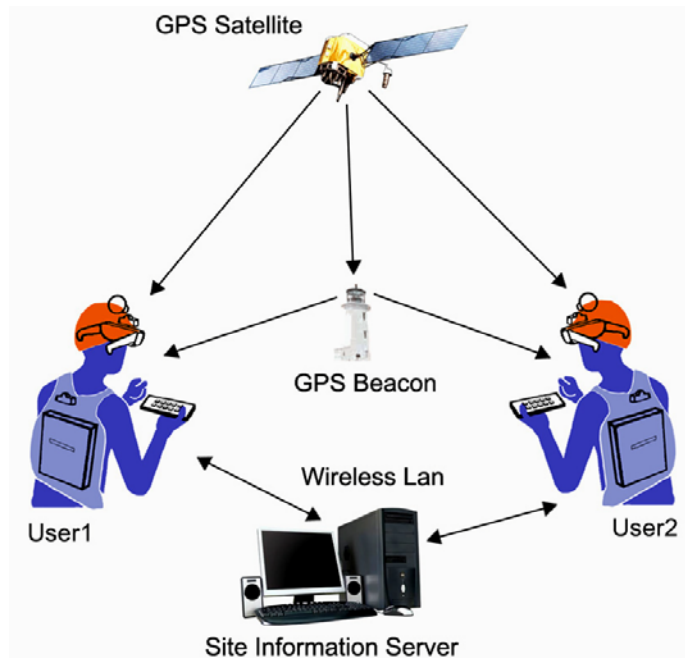

Figure 6 Proposed system architecture

The initial prototype system is self-contained, where all the data presented to the user is store locally on the mobile unit, so a Wireless Local Area Network (WLAN) interface is required (Figure 6). This also allows communication with other mobile units (other participants) in the same area. The WLAN is used to synchronize certain presentations for the user group with a centralized site-server distributing updated datasets and keeping track of individual units on-site.

In summary, the hardware components of the system include a Site Information Server, Mobile Unit, and WLAN.

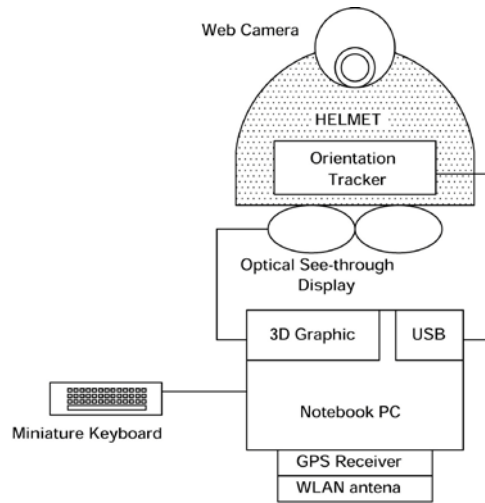

Figure 7 Wearable PC model

3.3 Wearable PC devices (Mobile Unit)

The proposed outdoor AR system prototype basically consists of two main components working in parallel. In addition to the software part of the system, several supporting hardware devices are used to provide input and output data, including a GPS receiver, orientation tracker (electronic compass), and Head Mounted Display (HMD). The miniature keyboard (Phoenix forearm-mounted keyboard) also is used for manual entry data.

Clearly, the main module of the mobile device set needs to provide suitable interfaces for all the peripheral devices and also drive them. Thus, for the case of outdoor working in real-time, special care must be taken regarding the power consumption of the various components, as well as the power supply included in the mobile device set. Figure 7 presents the wearable computer prototype (in a backpack), and Figure 8 shows how the device set is used in the case of firemen.

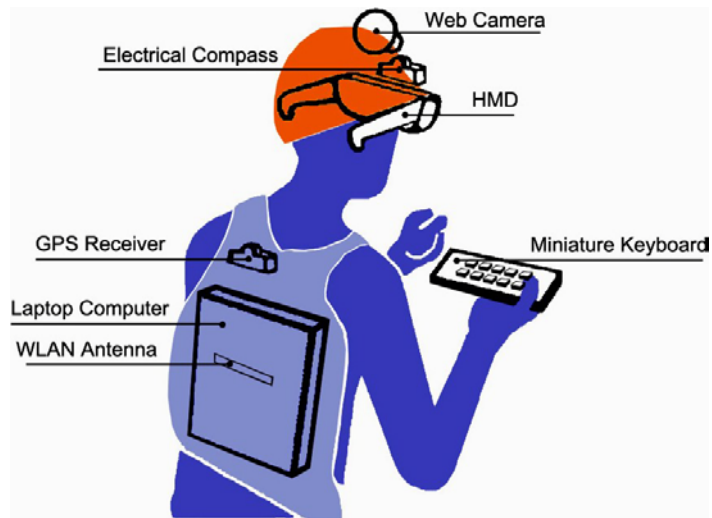

Figure 8 Mobile unit device (equipped for ordinary AR user or fireman)

GPS receiver and orientation tracker

A Garmin eTrex HCX GPS receiver together with an InterSense Intertrax2 head tracking system were used for the first prototype (Figure 9). Although the accuracy level obtained from the GPS used in the prototype phase was around 3 meters, the user’s position and orientation collected in this phase could still be used in the next phase by performing a one-time calibration just after the AR software starts capturing live scenes. However, in future, a more accurate GPS system that can easily be adapted for use with the AR software would lead to more practical results.



Figure 9 Garmin eTrex HCX GPS receiver and InterSense Intertrax2 fixed on Optical See-through Display (i-Glasses- Scape II HMD)

Head-mounted Display (HMD) and camera

The HMD mainly consists of two parts: a video input device and see-through display. Almost any kind of video input device can be used as the live video stream capture device (i.e. webcam or camcorder).

Yet, since the main aim of this study is to provide an AR scene for firemen working under severe conditions, the system needs to leave the hands free. Therefore, an I-Glasses Model I-Scape II is used to superimpose virtual objects on the real scene. While the user can still see the real life scene, the virtual graphics are overlaid on transparent glass. Figure 10 shows an example of how the components of the Augmented Reality system work together to produce the final result on an optical see-through display.

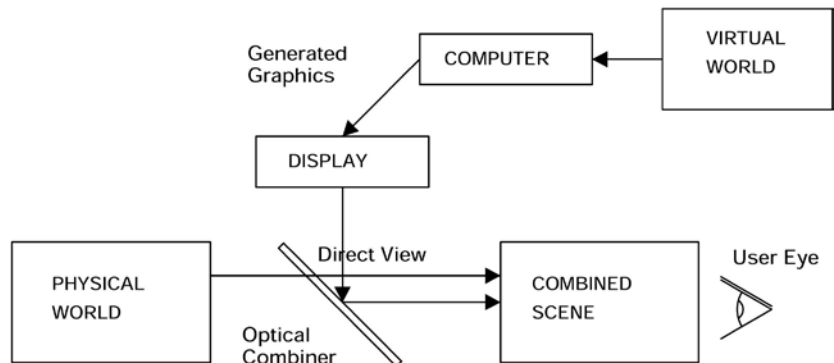

Figure 10 Schematic illustration of optical overlay-based Augmented Reality

The determination of the user's exact position and orientation parameters, so-called pose, is based on a video tracking algorithm that analyzes the user's current view of special features, which is why the camera has to be attached to the display unit, permanently capturing the field-of-view and transferring the image sequence to the Mobile Unit's main module. The more images the system can process, the more accurate the pose that can be extracted. Consequently, there are two primary requirements for a suitable camera: the image quality and the maximum frame-rate it is able to capture. In the present study, a Logitech QuickCAM Vision Pro Webcam (which can support a resolution of 1600x1200 pixels) is used as the video input device.

Portable PC

For the user to be able to move freely around in the real world, the system should be placed in a manner that can be easily carried and accessed anywhere. Thus, a Compaq HP V3000 laptop with a 2Ghz CPU speed and 2GB memory is used. Finding an optimum balance between the processing power and the battery life on one hand and portability on the other hand is always an important issue in this step for almost any outdoor AR application. For the more powerful the computer system, the heavier it is to carry around.

3.4 Software

Due to the advantages of a modular platform over an integrated platform, the main goal is to keep the software as modular as possible. Thus, the final result is a series of independent interconnected modules that can be simply replaced or updated when needed. The current AR software is a platform on which four different modules act simultaneously and produce a unique output that can be seen through the HMD.

The first module is a unit that captures the live video stream from the real environment using the video input device. The second module is mainly a data collector from the GPS receiver that provides the software with the user's global position in terms of the longitude, latitude, and altitude. The third module is a data collector from the orientation tracker which basically gives out three head rotation angles around each axis in real simulation time. The fourth module is essentially a graphical module which reads the data from the linked files and places each virtual model in the user's view on a real-time basis. Using these modules and knowing that the location and orientation of objects must be kept independent of the user's position and orientation, for any transformation of the user, a reverse transformation is calculated and applied to the objects in the user's view so that the graphics always appear fixed to a particular location.

Having a modular platform makes it possible to choose between a wide variety of input and output devices and resources and still obtain satisfactory results from the AR software. For example, data for virtual objects can be input to the software using the format of CAD models (3DS, VRML, etc). In any case, the software is capable of collecting usable data, such as dimensions and global coordinates, for any virtual object presented in the data file and inputting them to the corresponding modules for further procedures, such as translation and rotation. At the same time, the user's position and orientation are obtained from the GPS receiver and orientation tracker connected to a part of the user's body, and

using this data, the AR software can then develop a perspective viewing frustum visible through the HMD. As the user moves around, user movements are detected and a relative transformation matrix is calculated and updated.

Applying the inverse of this transformation matrix to the virtual objects in the viewing frustum, the AR software tries to keep them in a fixed position so that they are not affected by the user's movement. To give an example, a virtual object that is visible with a specific combination of the user's position and orientation should not be visible when the user turns 180 degrees around. To do so, a -180 degree rotation should be applied to the object so that it becomes outside the user's view. Meanwhile, some new objects may become visible after applying a -180 rotation matrix to the original coordinates. Figure 11 illustrates the schematic flowchart used by the software when reading virtual object data from a CAD file.

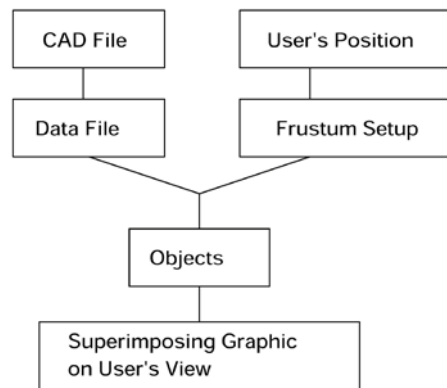

Figure 11 Basic steps taken by AR software when reading virtual object data from file

4 Implementation

4.1 Scenario

This system was tested in an outside environment within the context of visiting a virtual model of Namdaemun Gate to obtain technical information about it. The user wore a wearable computer device and started the experiment with a wireless network interface (WLAN) running from the Site Information Server. At the real site, a life-size virtual Namdaemun Gate was overlaid and the user was able to walk around and view it. When the user turned their head in a different direction, the transformation data from the electrical compass on the helmet helped the system to provide a suitably rotated angle of the virtual object. Actually, the AR user was able to walk inside the virtual traditional building and the outdoor AR system provided full coverage of interior space. The user clicked a button on a miniature keyboard (Phoenix forearm-mounted keyboard) when he or she wished to see more technical information on the virtual Namdaemun Gate.

In this case, some results for extra technical information are presented. For example, the outline graphics of the columns set or technical notations of the timbered components or main wooden framework can be enhanced to superimpose on the virtual building graphic. Upon choosing any option, a correlative virtual element can be drawn on the head display and superimposed on the actual scene.

Furthermore, based on the HMD's headphones, the user can also retrieve annotations or vocal instructions directly from another person participating in the same activity.

Therefore, the above results demonstrated the suitability of the prototype system for the purposes of cultural architectural education and practical training. The outdoor AR system also allows firemen to train following a real script, work together in the same outdoor AR system, and obtain additional information in real-time.

4.2 Operation for fire protection training

In a fire control context, one of the big issues is that firemen must approach and dismantle a dozen complex wooden components that are unknown to them. For instance, in an obvious emergency situation, fire-fighter teams attending Namdaemun for the first time are given a mission to approach a predefined point of the fire. To do so, they must dismantle a dozen components according to the system guide simultaneously. In order to discuss the procedure before the fire fighting operation, the prototype outdoor AR system can direct firemen teams to realize component shapes before they even visit the site. And then onsite, the wearable AR device set can assist firemen to identify required wooden components as they approach the building.

However, in the case of fire protection training for extensive complex traditional buildings (e.g. palaces or mausoleums), assisting firemen teams to approach, access and move across the buildings in different ways is of critical importance. This enables firemen teams to carry out a much more cohesive and informed collaborative operation. Thus, instead of executing repeated fire-fighter training at a valuable if complex traditional building, the prototype AR outdoor promises to create complex virtual buildings that appear to be life-size on real site. It is designed to be robust and informative even after repetitive training sessions. Here, several participants equipped with Mobile Unit (wearable devices) would find it easy to approach and observe a range of complex components of a building. For training to produce good results, the outdoor AR system also can support AR aviation view (Figure 12-Left) in order for team leaders to observe the overall rescue operation, so that they can propose suitable commands for firemen teams for specific situations. The proposed AR system is also expected to be of value in the case of real emergencies. However, further improvements in AR hardware are still needed in order to withstand severe conditions.



Figure 12 Left- Namdaemun in AR aviation view, Right- A life-size 3D model overlaid on the real gate

4.3 Test results

The following describes the system operation. In this experiment, although the actual location of the Namdaemun Gate was not used, the main purpose was to demonstrate life-size 3D virtual graphics of Namdaemun Gate in an outdoor environment. All the participants were able to see views of the virtual Namdaemun Gate matching their respective locations (Figure 12). In this hypothetical example, they can be firemen who need to carry out practical courses in extinguishing fire. The group discussion for planning execution of the mission is facilitated through this outdoor AR system. When required, the particular components of the building were added (main column set, bracket set, roof beam, timbered specifications, etc.), providing the user with specific architectural information (Figure 13). The result showed this prototype would prove worthwhile for training firemen to successfully extinguish fires. Nonetheless, the robustness and weight of the Mobile Unit are still important problems that need to be addressed in further studies.

Figure 13 Left- Users carried a wearable PC and roamed freely around & into the virtual building. Right- The technical notices were turned on by button commands on a miniature keyboard



5 Future work & challenges

The current stage of the research is mainly focused on the positioning problem of virtual models in augmented space. There are also other issues that should be considered in future steps of developing the present AR platform that can be mainly grouped as scaling, geographical database interaction, and occlusion problems.

The very first step that should be taken after the positioning problem is solved, is adding the ability to the AR platform to dynamically acquire scale factors and update the size in every direction for each of the superimposed virtual object throughout the AR application runtime.

Geographical database interaction mostly deals with adapting the AR platform to obtain data from GPS systems so the position of the AR system user and virtual objects and also the characteristics of the surrounding environment are more accurate, realistic, and easy to update. In order to do that, the use of GPS receivers seems to be very helpful and practical as in an outdoor environment, reliable output can be well obtained using a GPS receiver with a high accuracy level.

Occlusion happens when a real object is placed between the user's view and the virtual objects in his view. In that case, as the distance between the real object and the user is less than that of virtual objects and the user, the real object can potentially block the user's view by moving into his view frustum. A possible

solution for that is using the depth of field (z-buffer algorithm) in which the depth of the real object is detected and compared with the depth of each of those virtual objects. If this depth is greater than the depth of virtual objects, the real object is not going to affect obstacle any virtual object and the user's view is not affected. Otherwise, appropriate corrections should be made to user's view to take into account the existence of such a close real object.

6 Conclusions

This study proved the feasibility and potential of using a mobile outdoor Augmented Reality system for disaster prevention or restoration, as well as a tourist guide of traditional buildings, and for educational purposes in a real outdoor environment.

In this study, the wooden framework architecture of Namedaemun Gate was reviewed as a new application of Augmented Reality for Korean Historical Buildings. As such, the components were presented based on a 3D model of the wooden framework, including the animated joints and joining of the component groups to illustrate the framework construction interactively in a real-time simulation.

AR technology opens up new research fields, especially in engineering and architecture. In an outdoor AR environment, the architecture exploration process becomes more convenient and more intuitive, as the architecture work and relative operations can be investigated and manipulated at the same time.

Furthermore, outdoor AR can also be an animated simulation tool of historical buildings at real sites, allowing the user to view restored buildings through an HMD, video display, or PDA. Thus, the potential uses of outdoor AR are expected to increase, especially for architecture education and disaster prevention in the case of Korean traditional buildings. However, our research would be continued in future works, which are focused on improvements of functional operations and for enhanced AR hardware usability especially for fire fighting work.

Bibliography

- Azuma, R.** (1997). A survey of Augmented Reality, Presence: Teleoperators and Virtual Environment, Citeseer, USA, 6: 4, pp. 355-385
- Azuma, R.** (2000). The challenge of Marking Augmented Reality Work Outdoors. In: Ohta Y. & Tamura H. eds, Mixed Reality: Merging Real and Virtual World, Springer- Verlag, Japan, pp. 363-384
- Azuma, R.** et al (1999). A Motion-Stabilized Outdoor Augmented Reality System. In: Proceedings of the Virtual Reality Conference, IEEE, Houston, USA, pp. 252-259
- Bass, L.** et al (1997). The Design of a Wearable Computer, Proceedings of the SIGCHI conference on Human factors in computing systems, ACM, New York, USA, pp. 139- 146
- Behringer, R.** et al (2000). A Wearable Augmented Reality Tested for Navigation and Control, Built Solely with Commercial- Off- The Shelf (COTS) Hardware. In: Proceedings of the ISAR'00, IEEE, USA, pp. 12-19
- Billinghurst, M.** et al (2000). Mixing Realities in Shared Space: An Augmented Reality Interface for Collaborative Computing. In: Proceedings of ICME, IEEE, USA, pp. 1641-1644
- Cultivate Interactive** (2003). Augmented Reality Touring of Archaeological Sites with the AR-CHEOGUIDE System, Cultivate Interactive Organization [www.cultivate-int.org/issue9/archeoguide/index.html]
- Garmin Company** [www.garmin.com]]
- I-O Display Systems** [www.i-glassesstore.com]]

- Kensek, K.** et al (2000). Augmented Reality: An application for Architecture. In: Proceedings of the 8th International Conference on Computing in Civil and Building Engineering, ASCE, Stanford, CA, USA, pp. 294-301
- Milgram, P.** et al (1994). Augmented Reality: A class of displays on the real- virtuality continuum. In: Proceedings of the Telemanipulator and Telepresence technologies, SPIE, Bellingham, Wash, vol. 235, pp. 282-294
- Pierkarski, W.** et al (1999). Integrating Virtual and Augmented Realities in an Outdoor Application. In: Proceedings of the 2nd IWAR, IEEE, Washington DC, pp. 45-54
- Stricker, D.** and **Kettenbach, T.** (2000). Real-time and Markerless Vision- based Tracking for Outdoor Augmented Reality Applications. In: Proceedings of ISAR'01, IEEE, Washington, pp. 189
- Thomas, B.** et al (2000). ARQuake: An Outdoor/Indoor Augmented Reality first person application. In: Proceedings of the 4th International Symposium on Wearable Computer, IEEE, Atlanta, GA, pp. 139-146
- Woodward, C.** et al (2007). Virtual and Augmented Reality in the digital building project, *International Journal of Design Science and Technology*, 14: 1, pp. 23-40
- Zalatanova, S.** (2002). Augmented Reality Technology, GIST N°17, GIS technology, TU Delft, The Netherlands

Instructions for Authors

All papers are reviewed by at least two reviewers. All reviewed and accepted papers have to be resubmitted, implementing reviewers and editors comments or suggestions. Only accepted papers conforming to instructions will be considered for publication in the *International Journal of Design Sciences and Technology*.

The first page of the paper must contain the full title of the paper as well as the name, affiliation, address, telephone, fax and email of the main author and co-authors (if applicable). Also mention the name, postal address, telephone, fax and email of the author to whom all correspondence to be directed.

The second page should contain the full title of the paper, the sub-title (if any), an abstract of 100 to 150 words summarising the content of the paper and 3-5 keywords for the purpose of indexing (the use of references in the abstract is discouraged). Maximum length of a long paper is 7000 words (4000 words for short papers). Please note that the use of Footnotes and endnotes are discouraged. The layout of the journal allows the use of 'side notes' (see a sample issue of the journal). Where appropriate give information for the 'side notes' (maximum length 60 words) between double square brackets (such as full bibliographic reference, page numbers, remarks and notes). All side notes should be numbered consecutively. For instance: [[17 A 'side note' reflects additional information, a reference or the URL of a website]]

The paper will be written in (UK) English. It will be single-spaced with 30 mm margins on all sides (paper size A4). Use Times New Roman for the main body of text (size 10), figures (size 8) or tables (size 8). The use of **Bold**, *Italics*, ALL CAPS, SMALL CAPS, etc. is discouraged. All chapters should be numbered consecutively (more than one level sub-headings are discouraged). All Figures and Tables with their respective captions should be numbered consecutively. They should each, be placed on a separate page, at the end of the paper. All figures, tables and equations should be mentioned in the body of text. Give an approximate insertion point for figures and tables, between double square brackets. For instance: [[insert Figure 5]]. You will be asked to resubmit your drawings if necessary. **Do not layout your paper. Do not use any styles or any automatic layout system.** Please do not use 'Track Changes'.

All Tables should be referred to in the text as Table 1, Table 2, etc. All Figures should be referred to in the text as Figure 1, Figure 2, etc. Line drawings should be of good quality. Use light background if possible (white is preferred). Photographs and screen-shots should also be submitted separately as JPEG files (use high resolution for better results). Authors should prepare high quality figures and drawings. Avoid the use of colours in your illustrations, as the journal is not published in colour. Maximum width and height of a figure are respectively 115 (150 mm if absolutely necessary) mm and 190 mm. Maximum width and height of a table are respectively 115 mm (150 mm if absolutely necessary) and 170 mm. All Equations will be numbered consecutively and should be mentioned in the text.

Use 'Harvard System of Reference'. Bibliography (references) is collected at the end of the paper, arranged in alphabetical order by the first author's surname, followed by initials. All authors should be mentioned. Dates will appear between brackets after the authors' name(s). This is followed by the title of the book, name of the publisher, place of publication and page numbers (if applicable). To refer to a journal paper, add the full title of the journal followed by Volume:Issue Number

and page(s). Examples of references to a book, a journal or a website are shown below:

- Dixon, N.M.** (2000). *Common Knowledge: how companies thrive by sharing what they know*, Harvard Business School Press, Boston, MA
- Buxton, W.** (1997). *Living in Augmented Reality: Ubiquitous Media and Reflective Environments*. In: Finne K., Sellen A. and Wilber S. eds, *Video Mediated Communication*, Erlbaum, Hillsdale N.J., pp. 363-384
- Beckett K.L.** and **Shaffer D.W.** (2004). *Augmented by Reality: The Pedagogical Praxis of Urban Planning as a Pathway to Ecological Thinking*, University of Wisconsin, Madison
- Djenidi H., Ramdane-Cherif A., Tadj C. and Levy N.** (2004). *Generic Pipelined Multi-Agents Architecture for Multimedia Multimodal Software Environment*, *Journal of Object Technology*, 3:8, pp. 147-169
- Gorard, S. and Selwynn, N.** (1999). *Switching on to the learning society? Questioning the role of technology in widening participation in lifelong learning*, *Journal of Education Policy*, 14:5, 523-534
- Blackman, D.A.** (2001). *Does a Learning Organisation Facilitate Knowledge Acquisition and Transfer?* *Electronic Journal of Radical Organization Theory*, 7:2 [www.mngt.waikato.ac.nz/Research/ejrot/Vol7_1/Vol7_1articles/blackman.asp]
- World Bank** (2002). *Social assessment as a method for social analysis*, World Bank Group [www.worldbank.org/gender/resources/assessment/samethod.htm]

Papers in their definitive version will be submitted as a MS Word file for the PC (MS Word RTF format for Macintosh). In addition, a formatted version of the paper (including images and tables) will be submitted in PDF format and all figures must be submitted in high resolution jpg or tiff format. Submit your paper as an email attachment to the Editor-in-Chief [beheshti@planet.nl]. You can also send your paper and images on a CD-ROM by an International Courier to:

Editor-in-Chief
International Journal of *Design Sciences and Technology*
Europa Productions
15, avenue de Ségur
75007 Paris, France

Author(s) have to complete, sign and return a *Copyrights Transfer Form* to the publisher. This copyrights transfer assignment will ensure the widest possible dissemination of information. Papers published in the International Journal of *Design Sciences and Technology* cannot be published elsewhere, in any form (digital, paper-based or otherwise) without a prior written permission from the publisher.

The author(s) are responsible for obtaining permission to utilise any copyrighted material. For more details about this subject, please contact the publisher at an early stage.

The decision of the Editor-in-Chief on all matters related to the International Journal of Design Sciences and Technology including the review process, publication of papers, etc. is final and cannot be disputed.

The leading author of a paper published in the International Journal of *Design Sciences and Technology* will receive a digital copy of the author's paper free of charge. Printed copies of any individual paper (minimum 50), any issue (minimum order 10 copies) and the Journal Year Book (one or more copies) can be purchased from the publisher (ask for an invoice from the address above or send an email to: ijdst@europa.org).

How to Order

International Journal of *Design Sciences & Technology*

IJDST-online

You can view and download a digital version of individual papers free of charge from the journal's website.

IJDST Hardcopies

Hardcopies of any individual paper (minimum order 50 copies), any issue (minimum order 10 copies) and volumes (minimum order is one single copy of the book containing 2 issues) can be ordered directly from Europaia Productions. You need to send your **Request for an Invoice** (preferably by email, Fax or letter) indicating details of your order and the quantities. Please provide your full name and initials, postal address, email and telephone number. An invoice will be sent to you indicating the total amount of your order, the cost of packing/postage and method of payment.

Individual Annual Subscription IJDST Hardcopies

Individual Annual Subscription to receive one hardcopy of the book containing two issues is €150.00 (incl. 5.5 % VAT, packing and postage) per annum. You need to send your **Request for an Annual Subscription Invoice** (preferably by email, Fax or letter) indicating the starting IJDST Volume. Please provide your full name and initials, postal address, email and telephone number. An invoice will be sent to you indicating the method of payment.

Institutional Annual Subscription IJDST Hardcopies

Libraries and organisations Annual Subscription to receive one hardcopy of the book containing two issues is €150.00 (incl. 5.5 % VAT, packing and postage). You need to send your **Request for an Annual Subscription Invoice** (preferably by email, Fax or letter) indicating the starting IJDST Volume. Please provide details of the library or organisation, name contact person, postal address, email, telephone number and Fax number. An invoice will be sent to you indicating the method of payment.

Other Publications

Other Europaia Productions publications can be ordered from the address below. You always need to send your **Request for an Invoice** (preferably by email, Fax or letter) indicating details of your order and the quantities. Please provide your full name and initials, postal address, email and telephone number. An invoice will be sent to you indicating the total amount of your order, the cost of packing/postage and method of payment.

Europaia Productions

15, avenue de Ségur, 75007 Paris, France

Telephone +33 1 45512607

Fax +33 1 45512632

E-mail: ijdst@europia.org

URL: europia.org/ijdst

International Journal of Design Sciences and Technology

Editor-in-Chief: **Reza Beheshti** and **Khaldoun Zreik**

Volume 17 Number 2

Issue Editor: **Reza Beheshti**

Table of Contents

<i>From distance shopping to virtual shopping</i> Kung Wong Lau, Pui Yuen Lee and Chi Wai Kan	77
<i>QFD for the building and construction industry</i> Bas van Loenen and Margot Mroczkowski	91
<i>A curriculum plan for digital information design</i> Gerry Derksen, James McKim Jr, Hemant Patwardhan, Cara Peters and Marilyn Sarow	107
<i>Developing outdoor augmented reality for architecture representation in educational activities</i> Viet Toan Phan and Seung Yeon Choo	121



1 6 3 0 - 7 2 6 7